



WASHINGTON METROPOLITAN AREA TRANSIT AUTHORITY
600 Fifth Street, NW, Washington, DC 20001-2651

AMENDMENT OF SOLICITATION / MODIFICATION OF CONTRACT

1. AMENDMENT/MODIFICATION Amendment 01	2. EFFECTIVE DATE August 30, 2017
3. ISSUED BY PURCHASING SECTION Sherry A. Caison Office of Procurement	4. ADMINISTERED BY (If other than block 3)
5. CONTRACTOR NAME AND ADDRESS (Street, city, county, state, and Zip Code)	6. FORM TYPE (Check only one) <input checked="" type="checkbox"/> AMENDMENT OF SOLICITATION NO. <u>FO18026</u> DATE <u>August 30, 2017</u> <small>(See block 7)</small> <input type="checkbox"/> MODIFICATION OF CONTRACT/ORDER NO. _____ DATE _____ (See block 9)

7. THIS BLOCK APPLIES ONLY TO AMENDMENTS OF SOLICITATIONS

The above numbered solicitation is amended as set forth in block 10. The hour and date specified for receipt of Offers is extended, is not extended. Offerors must acknowledge receipt of this amendment prior to the hour and date specified in the solicitation, or as amended, by one of the following methods; (a) By signing and returning _____ copies of this amendment; (b) by acknowledging receipt of this amendment on each copy of the offer submitted; or (c) by separate letter or telegram which includes a reference to the solicitation and amendment numbers. FAILURE OF YOUR ACKNOWLEDGMENT TO BE RECEIVED AT THE ISSUING OFFICE PRIOR TO THE HOUR AND DATE SPECIFIED MAY RESULT IN REJECTION OF YOUR OFFER. If, by virtue of this amendment you desire to change an offer already submitted, such change may be made by telegram or letter, provided such telegram makes reference to the solicitation and this amendment, and is received prior to the opening hour and date specified.

8. ACCOUNTING AND APPROPRIATION DATA (If required)

9. THIS BLOCK APPLIES ONLY TO MODIFICATIONS OF CONTRACTS/ORDERS

- (a) This Change Order is issued pursuant to _____
The Changes set forth in block 10 are made to the above numbered contract/order.
- (b) The above numbered contract/order is modified to reflect the administrative changes (such as changes in paying office, appropriation data, etc.) set forth in block 10.
- (c) This Supplemental Agreement is entered into pursuant to authority of _____
It modifies the above numbered contract as set forth in block 10.

10. DESCRIPTION OF AMENDMENT/MODIFICATION

1. This amendment is to include the Telephone Exhibits and Technical Specifications for the Telephones.

Except as provided herein, all terms and conditions of the document referenced in block 6, as heretofore changed, remain unchanged and in full force and effect.

11. <input type="checkbox"/> CONTRACTOR/OFFEROR IS REQUIRED TO SIGN THIS MODIFICATION AND RETURN _____ COPIES TO ISSUING OFFICE.	<input checked="" type="checkbox"/> CONTRACTOR/OFFEROR IS NOT REQUIRED TO SIGN THIS DOCUMENT		
12. NAME OF CONTRACTOR/OFFICE BY _____ <small>(Signature of person authorized to sign)</small>	15. WASHINGTON METROPOLITAN AREA TRANSIT AUTHORITY BY <u>Monique M. Anderson</u> <small>(Signature of Contracting Officer)</small>		
13. NAME AND TITLE OF SIGNER (Type or print)	14. DATE SIGNED	16. NAME OF CONTRACTING OFFICER (Type or print) Monique M. Anderson	17. DATE SIGNED 8/30/17

ETS Phone Specifications

Encapsulated circuit boards impervious to water, condensation, and dust
16 gauge corrosion protected steel enclosure with powder coat finish
Heavy duty industrial volume control and headset
Rust and corrosion resistant stainless steel hardware
Noise reducing microphone
Service temperature range (-76F to +176F)
Surge arrestor to prevent voltage spike damage
Hearing aid compatible
Electronic ringer
Modular parts for easy service
Waterproof keypad and curly cord
Voice quality unaffected when connected within 15,000ft of a main telephone switch supporting single line phones
Off hook detect relay

Electrical Performance

Audio Range Frequency Response - 300-3400Hz
Dialing Method - DTMF or 40/60 Pulse @10PPS
Transmit Objective Loudness Rating (TOLR) - Nominal -38+/-3dB
Receiver Volume Adjustment - 3 Steps Up/2 Steps Down 8.1dB/5.1dB
Receiver Objective Loudness Rating (ROLR) - Nominal 50 +/- 3dB
- receiver volume at maximum - 41.9 +/- 3 dB
- receiver volume at maximum - 55.4 +/- 3 dB
Side Tone Objective Loudness Rating (SOLR) - Nominal 11 +/- 4dB
- receiver volume at maximum - 7 +/- 4 dB
- receiver volume at maximum - 14 +/- 4 dB
Memory Dial - 10 Quick Dial Numbers 20 Digits Each
Flash - 600 mSec Timed Disconnect
Ringer Output - >85dB
FCC Ringer Equivalence - 0.8 B
Set Impedance - 600 Ohms Nominal

Maximum Loop - 15Kft (~4,600m) of 22AWG Wire

Electrical Requirements

Ringer Sensitivity - 40-100 v, 16-25 Hz

Line Voltage - 24-56 VDC

Loop Current - 20-120 mA

Connection Method - Terminal Block/Surge Arrestor

Mechanical Specifications

Hook Switch (Cradle Switch) Life - >1 000 000 Operations

Body Construction - 16Ga CRS Steel

Finish - Corrosion Protected & Powder Coated

Net Weight - 4.0 lbs.

Shipping Weight - 6.0 lbs.

Shipping Dimensions (HxWxD) - 15"x5"x11.5"

Hand Set Construction - High Impact ABS

Mounting - Vertical Wall

Microphone - Noise reducing Electret

Receiver - Hearing Aid Compatible

Hardware Material - Stainless Steel

Environmental

Temperature - Range of (- 76 F to + 176 F)

Humidity - 0-95% RH Con-Condensing

Corrosion Resistant - Full Gasket Faceplate

Exhibit IVa - Emergency Phone Style 2

SEE HANDSET DETAIL DRAWING FOR HANDSET DIMENSIONS

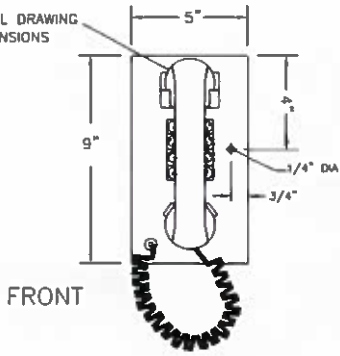

FRONT



5.25"



SIDE PROFILE

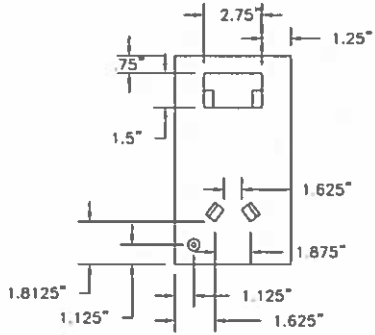

CRADLE LOCATION DETAIL

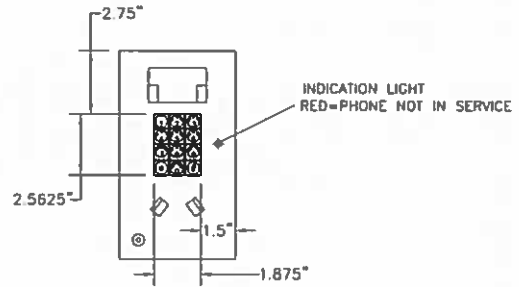

KEYPAD LOCATION DETAIL

DESIGNED BY	DATE	REFERENCE DIMENSIONS		REVISIONS				WAMATA IT NCS (Network & Communications Services)					
		NUMBER	DESCRIPTION	REV	DESCRIPTION AND REVISED BY	DATE		APPROVED BY	REV	DATE	BY		
DRIVEN								EMERGENCY PHONE STYLE #2					
CHECKED								FRONT DETAIL					
APPROVED							Glenn T						
									NTS				1 OF 1

Exhibit II - Emergency Phone Handset Detail

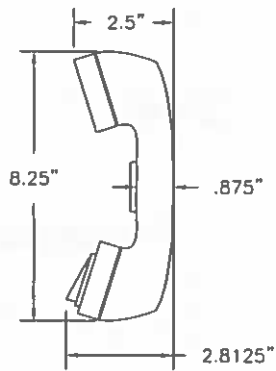

TOGGLE
HANDSET

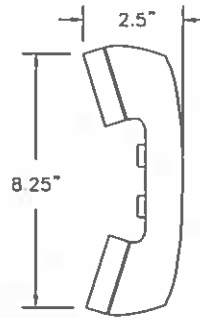
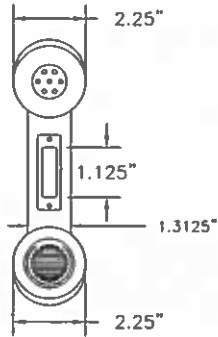

BUTTON
HANDSET

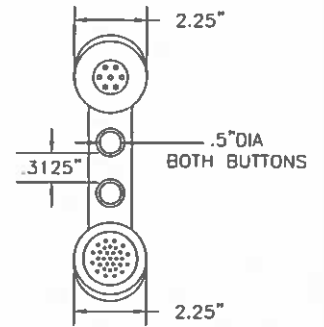

OVERALL DIMENSIONS
FOR BOTH HANDSETS
ARE THE SAME

DESIGNED BY	DATE	REFERENCE DIMENSIONS		DIMENSIONS		REV	DESCRIPTION	DATE	APPROVED BY
		CHANGE	REVISION	REVISION	REVISION				



OMATA IT MCS (Network & Communication Services)

EMERGENCY PHONE HANDSET DETAILS

Drawn by: Glenn T

Checked by: []

Approved by: []

1 OF 1

Exhibit III – Emergency Phone Style I

SEE HANDSET DETAIL DRAWING FOR HANDSET DIMENSIONS

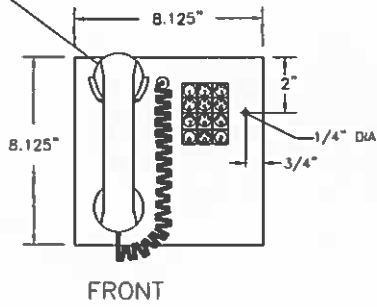

.375" HAND UNIT EXTENDS ABOVE BASE WHILE IN CRADLE

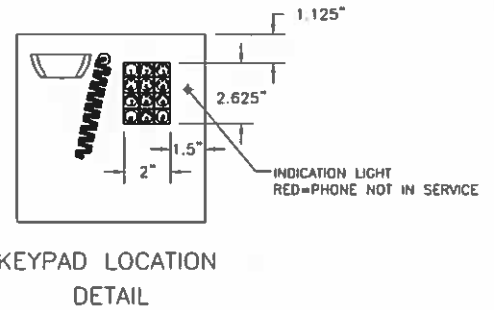
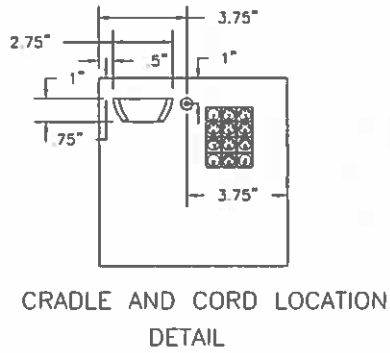
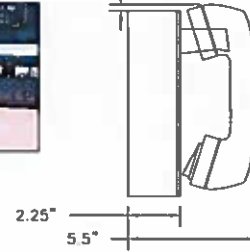

DESIGNED	DATE	BY	DATE	REVISIONS	DATE	BY	DESCRIPTION	APPROVED	DATE	BY



Model: **Style I**

WMAA IT NCS (Network & Communications Services)

EMERGENCY PHONE STYLE #1

Sheet: **1 OF 1**